

The ReliaWind logo features the word "ReliaWind" in a white, sans-serif font, with "Relia" in a standard weight and "Wind" in a bold weight. A light blue swoosh underline is positioned beneath the text. The logo is set against a dark blue rectangular background.

ReliaWind

The Gamesa logo consists of the word "Gamesa" in a blue, sans-serif font, positioned to the left of a circular icon. The icon is a stylized sun or turbine hub with multiple concentric rings and radial segments, all in blue.

Gamesa



An EC's FP7 funded R&D project
(EC Contract 212966)

- **RELIAWIND**
- **March 15th 2011**
- **Condition based maintenance tools for wind turbines and wind farms**
- **GAMESA**

0 DEFINITION:

What is a Condition based or "on-condition" monitoring?

Condition based or "on-condition" monitoring is a process where one or more parameters are monitored and trended over time. These parameters must have a direct relationship with the "health" of the equipment being monitored. On the basis of some threshold value (determined through analysis or experience) of a parameter or combination of parameters, the equipment will be repaired or replaced prior to any actual failure.

This approach to "scheduling" preventive maintenance can significantly reduce costs, prevent failures, and increase availability.

1 Design for Maintainability.

One of the most important aspects of designing equipment for maintainability is the breaking up of equipments into modules that are independent, interchangeable, and easily replaced. Partitioning the design such that components are grouped by functions (i.e., each function is implemented on a single FRU), or by technology (e.g., analog, digital) whenever possible will enhance the ability to isolate failures.

1 Design for Maintainability.



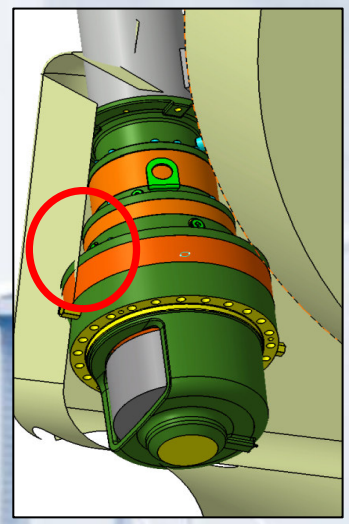
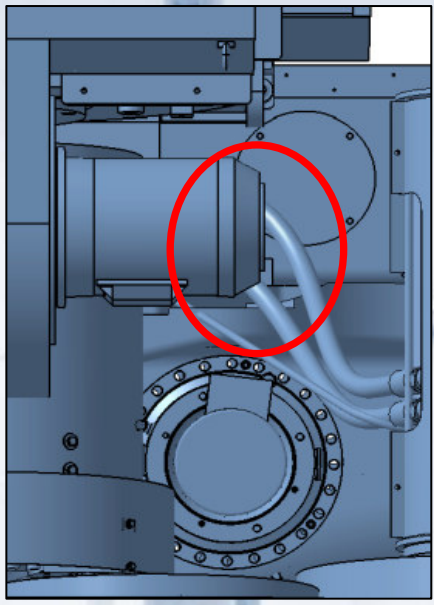

- Facilitate access to test points, data paths and internal circuitry should be provided to allow the test system (machine or human) to gather sufficient signature data for fault prognosis.
- Provide impending failure indications: Design components with wear out failures that clearly indicate when design limits are close.
- Condition Monitoring functions should be integrated with other performance monitoring functions.
- Reduce risk of maintenance-induced failures and false alarms.



2 Perform Functional Failure Mode Analysis

The relationship between availability and condition maintenance can be summarized as follows:

- Failures are inevitable in complex equipment and can never be entirely prevented by condition based maintenance.

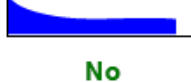
		UAL	Broberg 1973	MSDP Studies 1983	SSMD 1993	
Age-Related	Evidence of Wearout 	A.	4%	3%	3%	6%
	Age 	B.	2%	1%	17%	
		C.	5%	4%	3%	
Random		D.	7%	11%	6%	
		E.	14%	15%	42%	60%
		F.	68%	66%	29%	33%
No Evidence of Wearout		89%	92%	77%	93%	

Perform Functional Failure Mode Analysis (Cont.)

- Reliability can usually be dissociated from availability by the design features of the equipment.
- It is possible to design equipment so that very few of its failures or failure modes will be critical. In the case in which critical failure modes cannot be overcome by design, on-condition tasks and safe-life discard tasks can make the likelihood of a critical failure extremely remote.
- Condition based maintenance that do not relate to critical failures have no impact on availability. They do have an impact on operating costs, and their effectiveness must therefore be evaluated entirely in economic terms.
- Condition Based maintenance will include only those tasks which satisfy the criteria for both applicability and effectiveness. The applicability of a task is determined by the characteristics of the item and its effectiveness is defined in terms of the consequences the task is designed to prevent.

3

Define Potential and Functional Failures

- Functional failure is the inability of an item (or equipment containing it) to meet a specified performance standard.
- Potential failure is an identifiable physical condition which indicates a functional failure is imminent.

These parameters must have a direct relationship with the "health" of the equipment being monitored. On the basis of some threshold value (determined through analysis or experience) of a parameter or combination of parameters, the equipment will be repaired or replaced prior to any actual failure.

Examples of potential failure signs that can be detected are vibrations, cracks, particles in oil, temperature, noise, viscosity, color, etc.

3 Define Potential and Functional Failures (Cont.)

There are three criteria that must be met for an on-condition task to be applicable:

1. It must be possible to detect reduced failures resistance for a specific failure mode.
2. It must be possible to define a potential-failure condition that can be detected by an explicit task.
3. There must be a reasonably consistent age interval between the time of potential failure and the time of functional failure.



3 Define Potential and Functional Failures (Cont.)

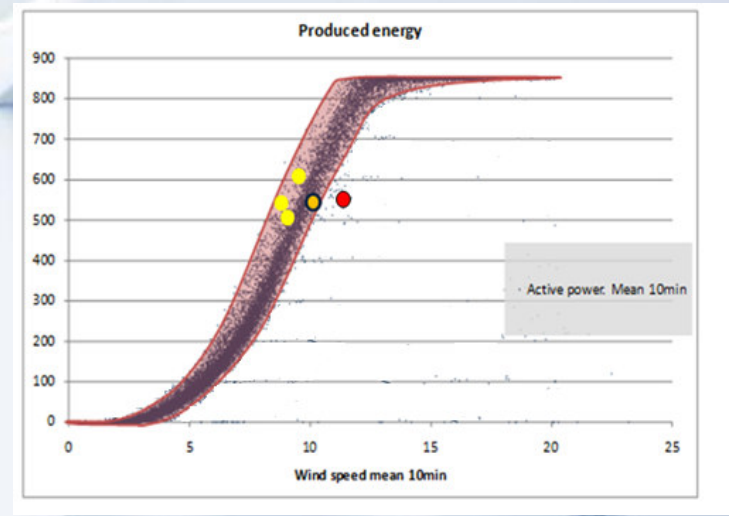
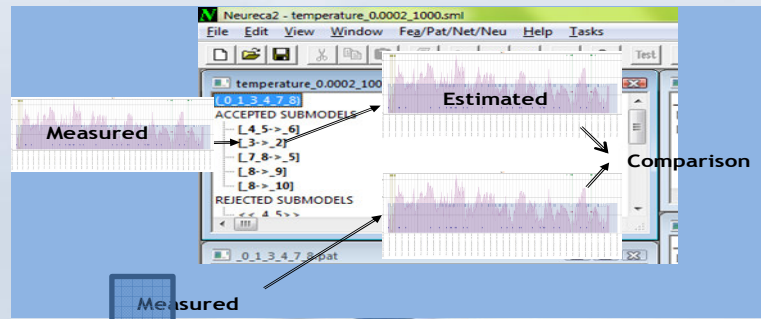

Non-conform situations

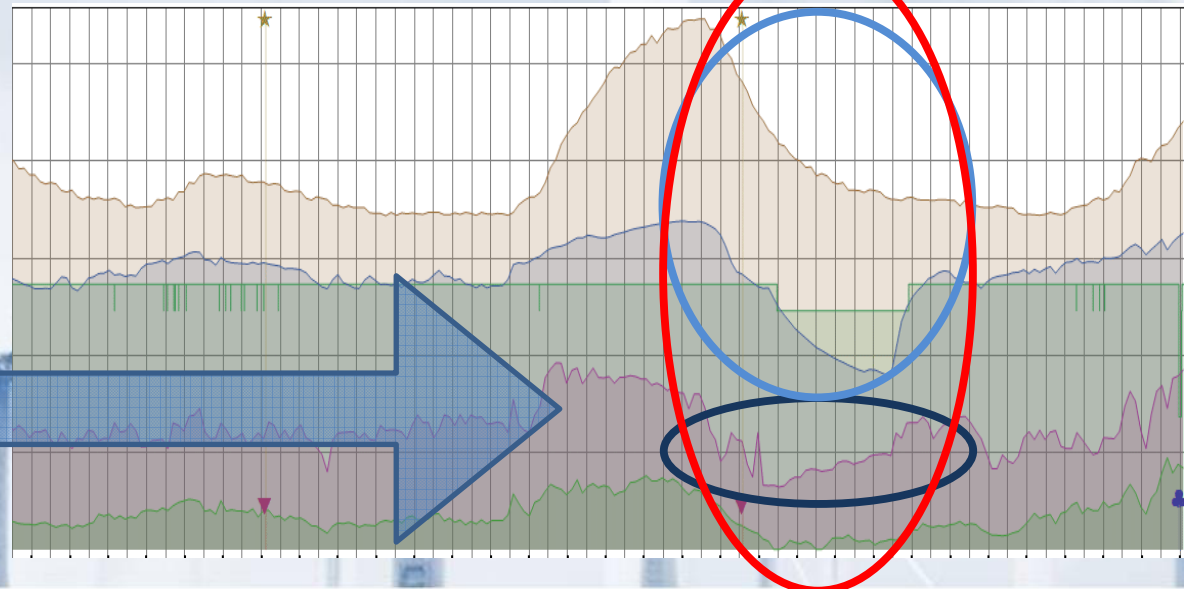
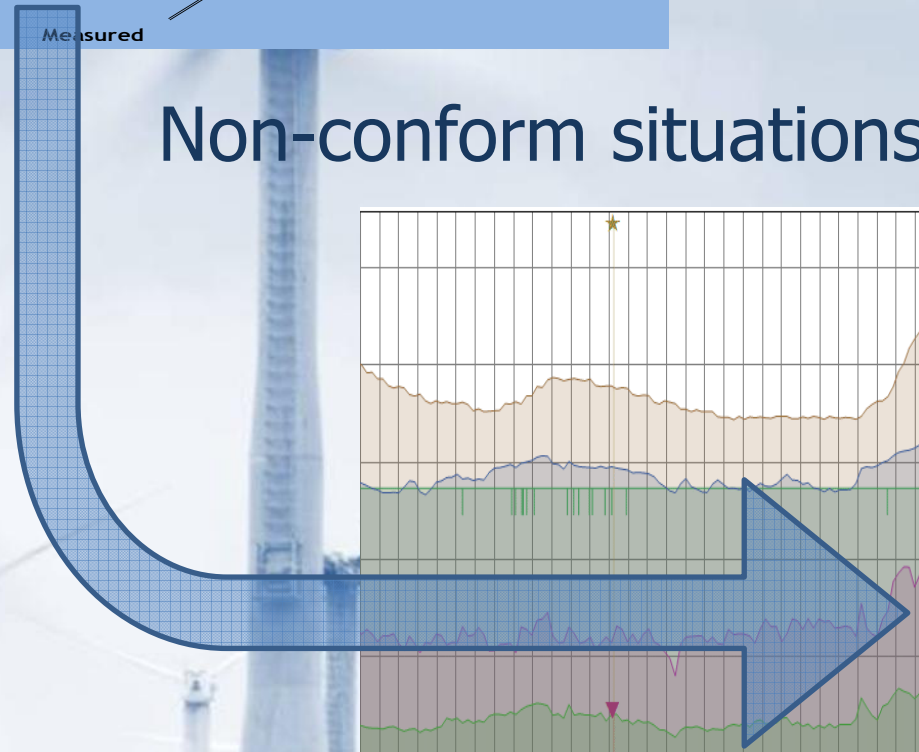

4 Define the Support Concept

A support concept means deciding on a run-to-failure or on-condition maintenance. Also whether data analysis will be performed at field, in the Wind Turbine Manufacturer or the supplier.

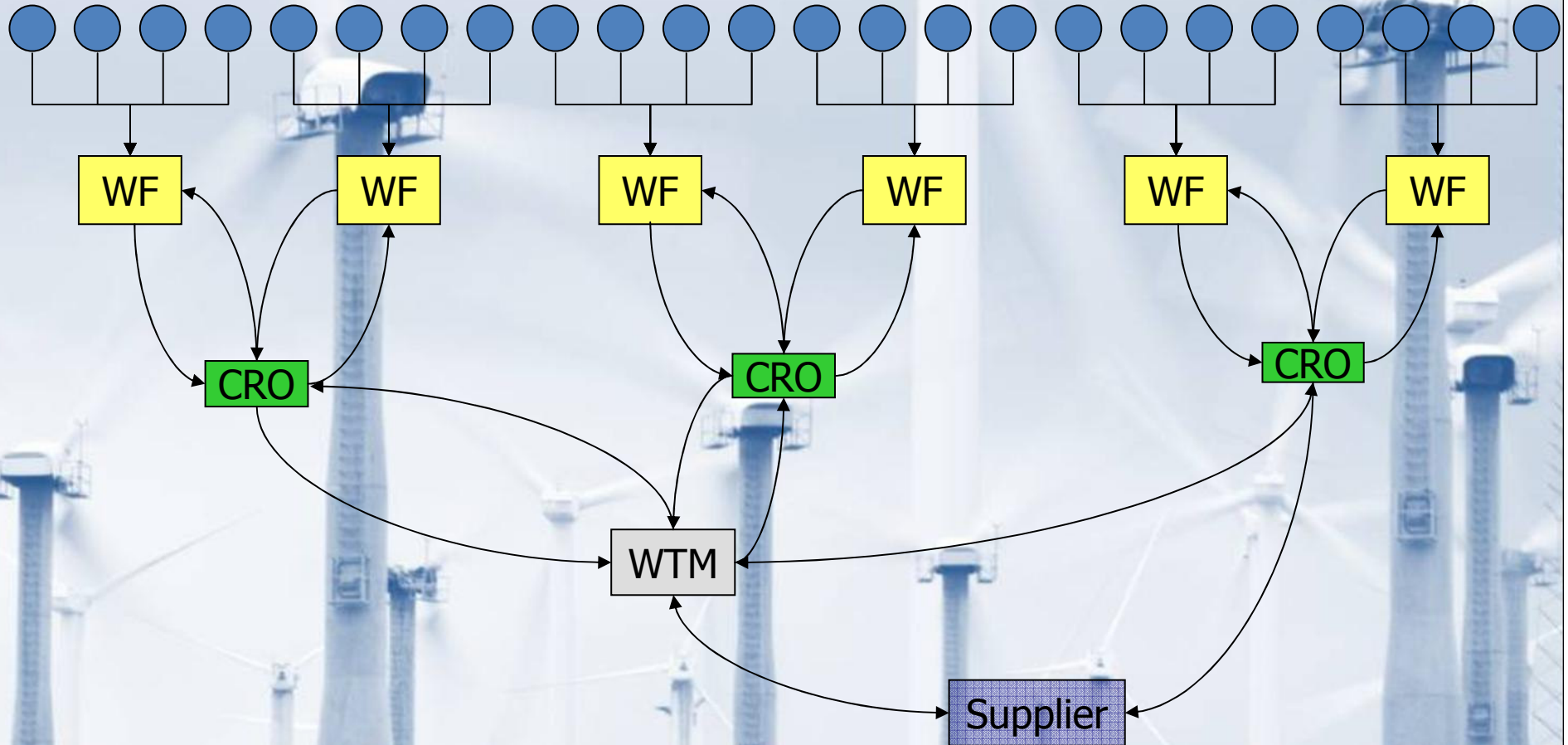

5

Optimize Results with Data Collection Efforts

- A condition based program must be dynamic; any prior to-service program is based on limited information, and the O&M organization must be prepared to collect and respond to real data throughout the service life of the WTG.
- Product improvement is a normal part of the development cycle for all new equipment.

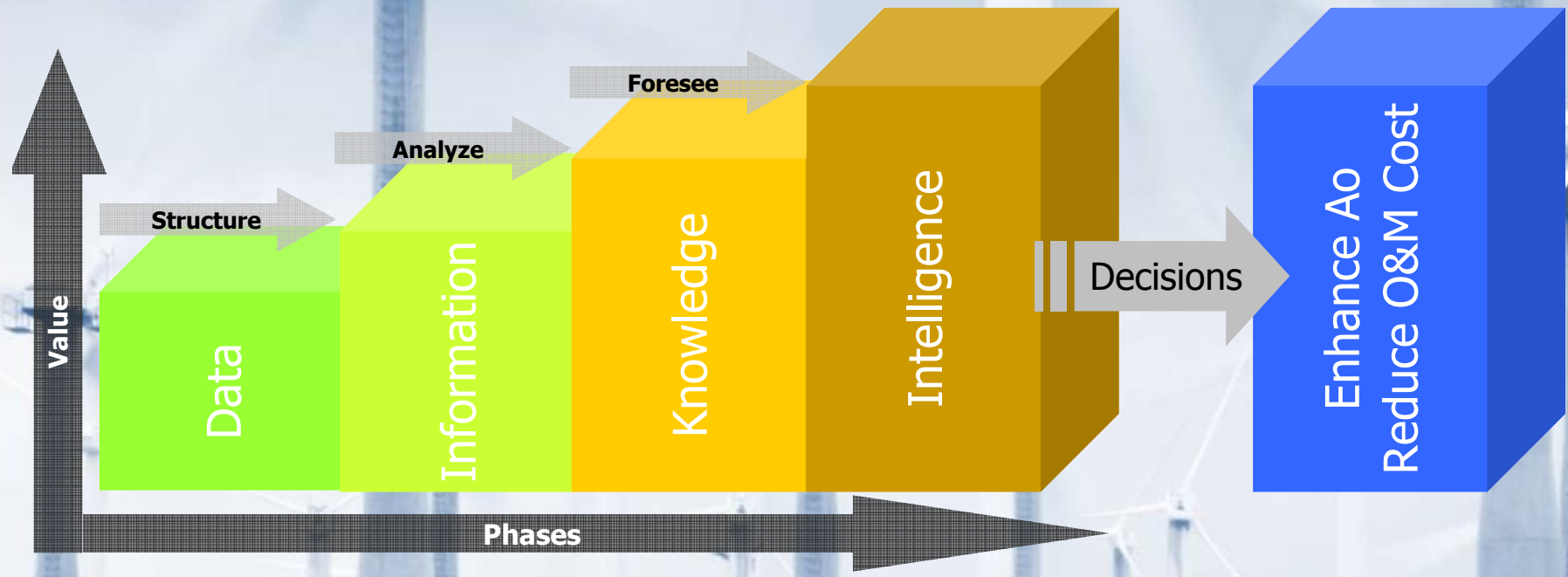

References.

- Reliability Centered Maintenance. F. Nowlan and H. Heap
- MIL-HDBK-470 Designing and Developing Maintainable Products and Systems
- S9081-AB-GIB-010 Reliability-Centered Maintenance (RCM) Handbook

Gamesa



Disclaimer

The present document, its content, its annexes and/or amendments (the "Document") has been made up by GAMESA CORPORACIÓN TECNOLÓGICA, S.A. ("Gamesa") for information purposes only, and contains private and confidential information regarding Gamesa and its subsidiaries (the "Company"), directed exclusively to its addressee. Therefore it must not be disclosed, published or distributed, partially or totally, without the prior written consent of Gamesa, and in any case expressly indicating the fact that Gamesa is the owner of all the intellectual property. All the content of the Document, whether it is texts, images, brands, trademarks, combination of colours or any other element, its structure and design, the selection and way of presenting the information, are protected by intellectual and industrial property rights owned by Gamesa, that the addressee of the Document must respect. In particular (notwithstanding the general confidentiality obligation), the addressee shall not reproduce (except for private use), copy, transform, distribute or publish to any other third party, any of the information, totally or partially.